



伟达电梯有限公司  
WELLIFT ELEVATOR CO., LTD.

# 无机房电梯 | V8-M

## THE MACHINE ROOMLESS ELEVATOR





伟达无机房电梯结合了传统曳引驱动和液压驱动的优点，并有着简化建筑设计、有效利用空间和节约建筑成本等独特优势，因而广受欢迎。

伟达基于最新曳引科技成果的开发应用，结合V8卓越的技术性能特点，推出了V8-M系列无机房电梯产品。

WELLIFT machine roomless elevator, combining with the merits of traditional traction drive and hydraulic drive, is widely accepted by customers with unbeatable advantages of simplifying building design, efficiently using space and saving constructing cost, etc.

Basing on the most advanced traction technology, combining with excellent technical performance of V8, now we develop the series of machine roomless elevators--V8-M.

## V8-M 适用范围 Application Scope of V8-M

目标市场	中低层住宅和商务楼
载重规格 (kg)	400, 550, 750, 900, 1000, 1150, 1350, 1600
速度规格 (m/s)	1.0, 1.5, 1.75
最大行程	60 m
最多停站	20
群控台数	8台
控制系统	模块化微电脑全集选控制
曳引机类型	永磁同步无齿轮

**Target market:** Medium-and-low residential building and business building

**Load (kg):** 400, 550, 750, 900, 1000, 1150, 1350, 1600

**Speed (m/s):** 1.0, 1.5, 1.75

**Max. travel:** 60 m

**Max. landings:** 20

**Group-control quantity:** 8 sets

**Control system:** Modular microprocessor full-collective control

**Type of traction machine:** Permanent magnet synchronous gearless drive



# 井道及机房布置图 Layout of well and machine room

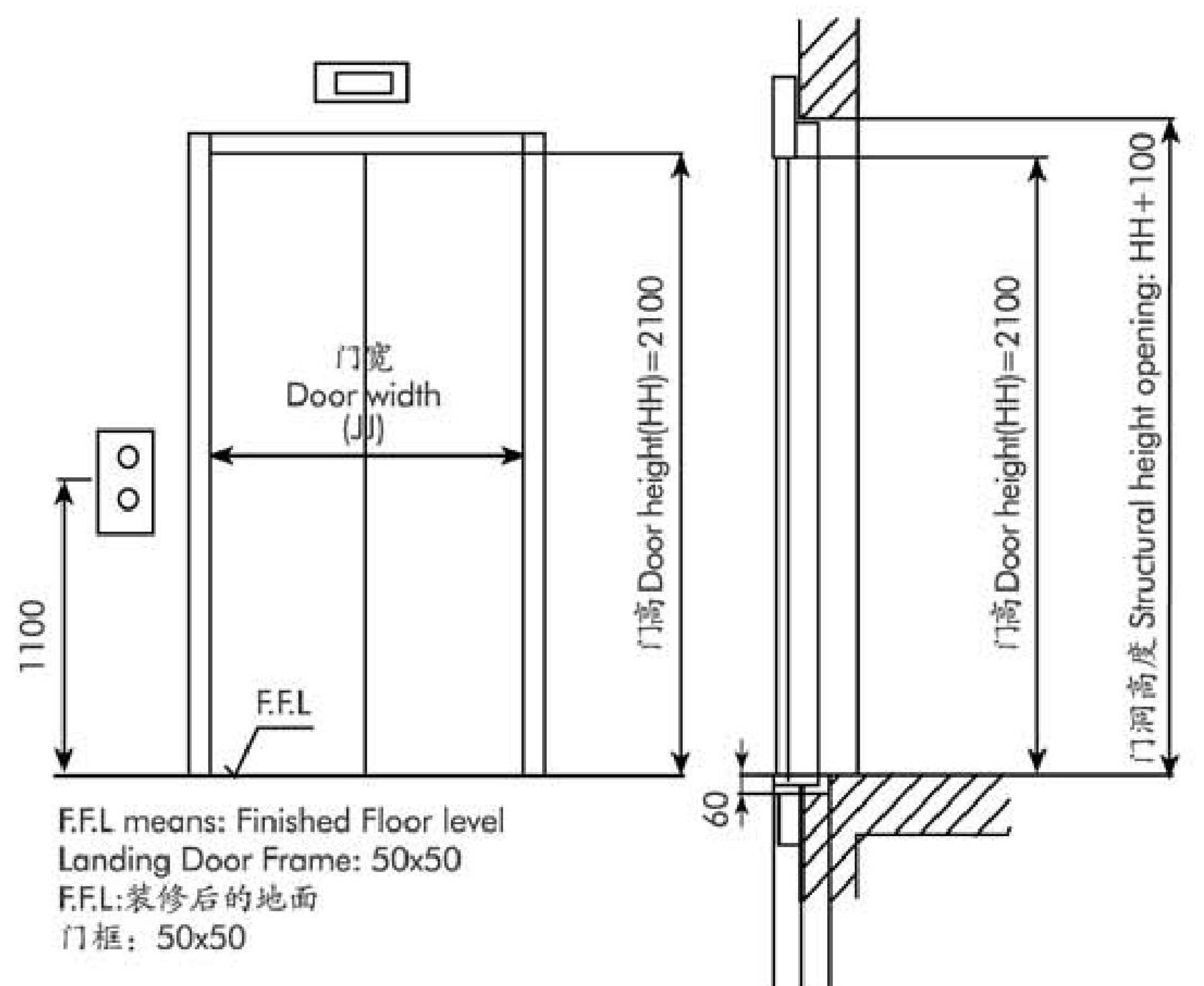
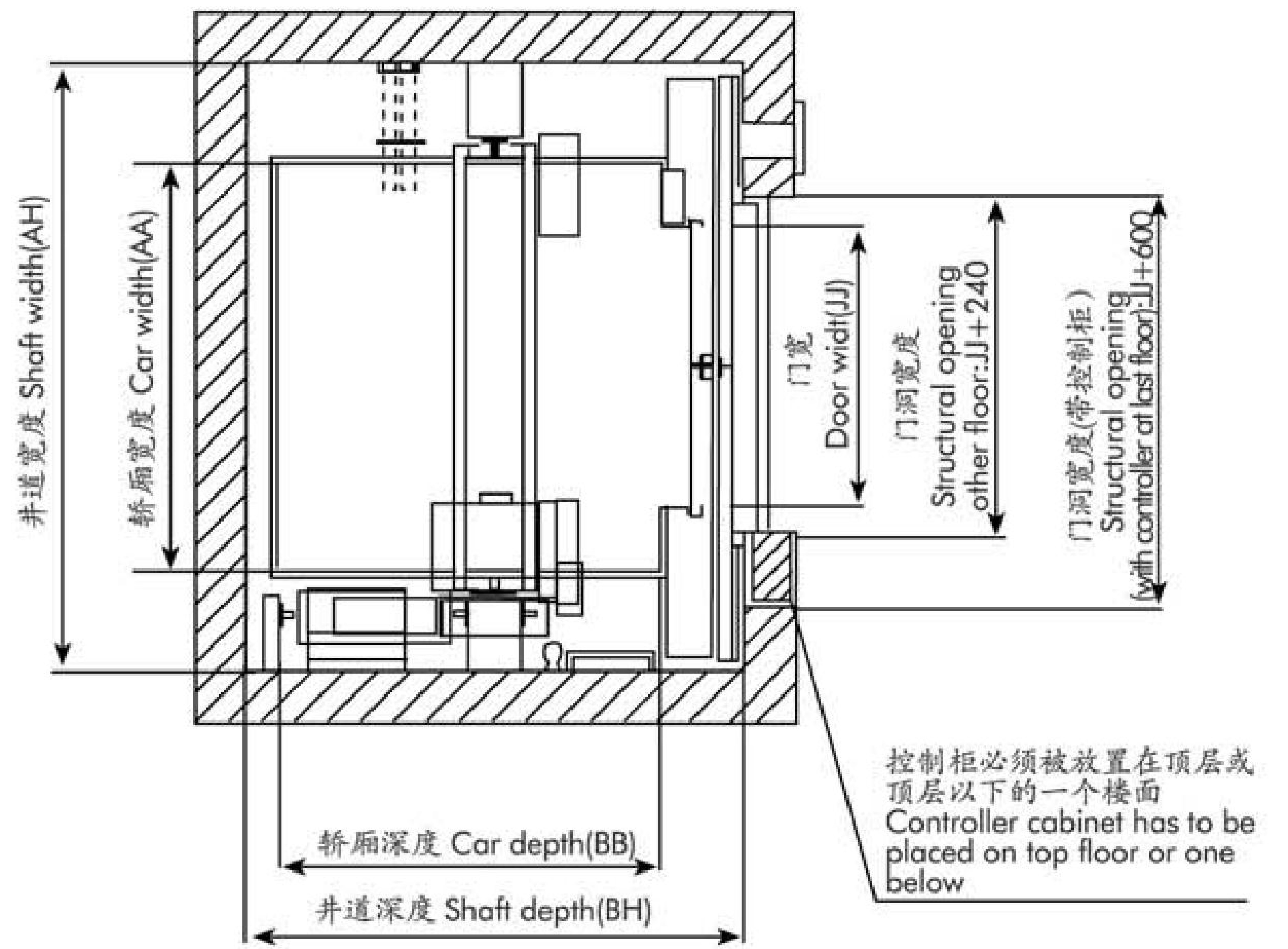


规格表 Specification Table

型号 Model	载重量 (kg)	载客量 Person	速度 Speed (m/s)	马达 Motor (kw)	开门 Entrance		轿厢尺寸 (宽*深*高) Car dimension AA x BB x H Inside	井道尺寸 Hoistway internal dimension			
					型式 Type	JJ x HH		AH x BH X x Y	PP	OH	
P400VF	24	400	6	0.4	1.25	中分 CO	800x2100	1100x1150x2300	2000x1650	1600	4000
	60			1.0	3.2						
P550VF	60	550	8	1.0	4.6	中分 CO	800x2100	1350x1200x2300	2250x1850	1400	4000
	90			1.5	6.8					1800	4300
	105			1.75	7.5					1800	4300
P750VF	60	750	10	1.0	5.5	中分 CO	800x2100	1350x1400x2300	2250x1900	1600	4200
	90			1.5	8.8					1800	4500
	105			1.75	9.6					1800	4500
P900VF	60	900	12	1.0	7	中分 CO	900x2100	1600x1350x2300	2500x1850	1600	4200
	90			1.5	11					1800	4500
	105			1.75	12.2					1800	4500
P1000VF	60	1000	13	1.0	7	中分 CO	900x2100	1600x1500x2300	2500x2000	1600	4200
	90			1.5	11					1800	4500
	105			1.75	12.2					1800	4500
P1150VF	60	1150	15	1.0	9.5	中分 CO	900x2100	1600x1600x2300	2500x2100	1600	4200
	90			1.5	14.9					1800	4500
	105			1.75	16.5					1800	4500
P1350VF	60	1350	18	1.0	9.5	中分 CO	1000x2100	1900x1600x2300	3000x2150	1600	4300
	90			1.5	14.9					1800	4600
	105			1.75	16.5					1800	4600
P1600VF	60	1600	22	1.0	11.2	中分 CO	1000x2100	1900x1850x2300	3000x2400	1600	4600
	90			1.5	17.7					1800	4600
	105			1.75	19.5					1800	4600

说明:

尺寸:

- 井道宽度与深度公差±25mm。
- 所给数据均为标准方案，细节及特殊尺寸请与我当地销售部门联系。

电源:

- 照明: 220V, ±10%; 50Hz, ±5%;单相, 带零线, 可靠接地。
- 动力: 380V, ±10%; 50Hz, ±5%;三相, 带零线, 可靠接地。

环境要求:

- 温度范围 +5~40℃。
- 机房月平均湿度不超过90%，日平均湿度不超过95%，不允许出现冷凝现象。

REMARKS:

Dimensions

- Shaft dimension width and depth are based on clear dimensions with ±25mm tolerances.
- All information for general reference and initial planning only. For specific construction details, please contact our local sales office. All information is subject to change without prior notice.

Power Supply

- Power supply for lighting :220V,single phase, fluctuation ±10%, neutral, earth.
- Power supply for VVVF drive: 380V,3 phase, fluctuation ±10%,neutral,earth. Mains frequency 50Hz, ±5%.

Ambient Conditions

- Temperature range 5~40℃ .
- Humidity in the machine room <90%, monthly average, <95%daily average,no condensation



C-S01型轿厢 Car



C-S02型轿厢 Car

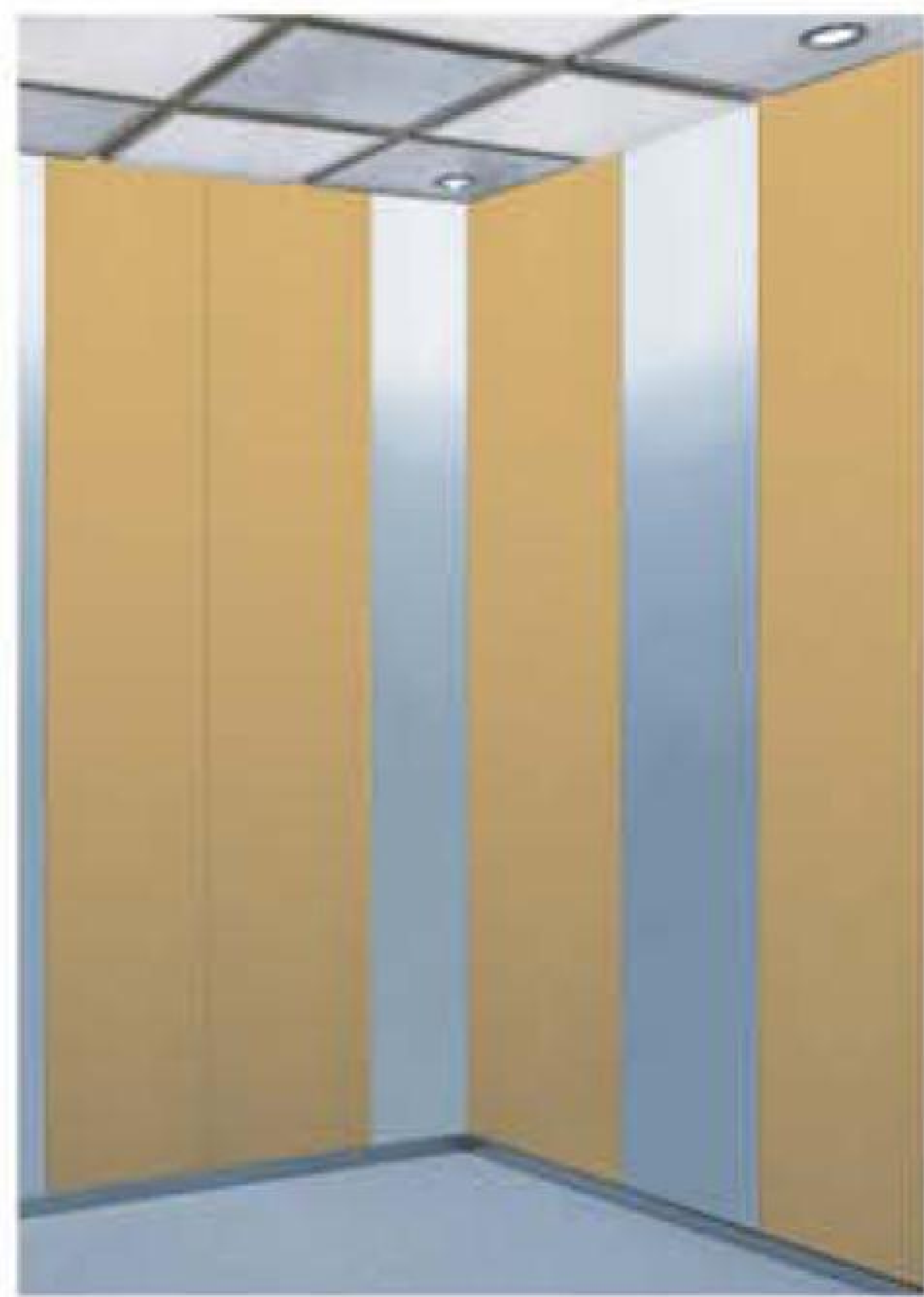

C-S03型轿厢 Car

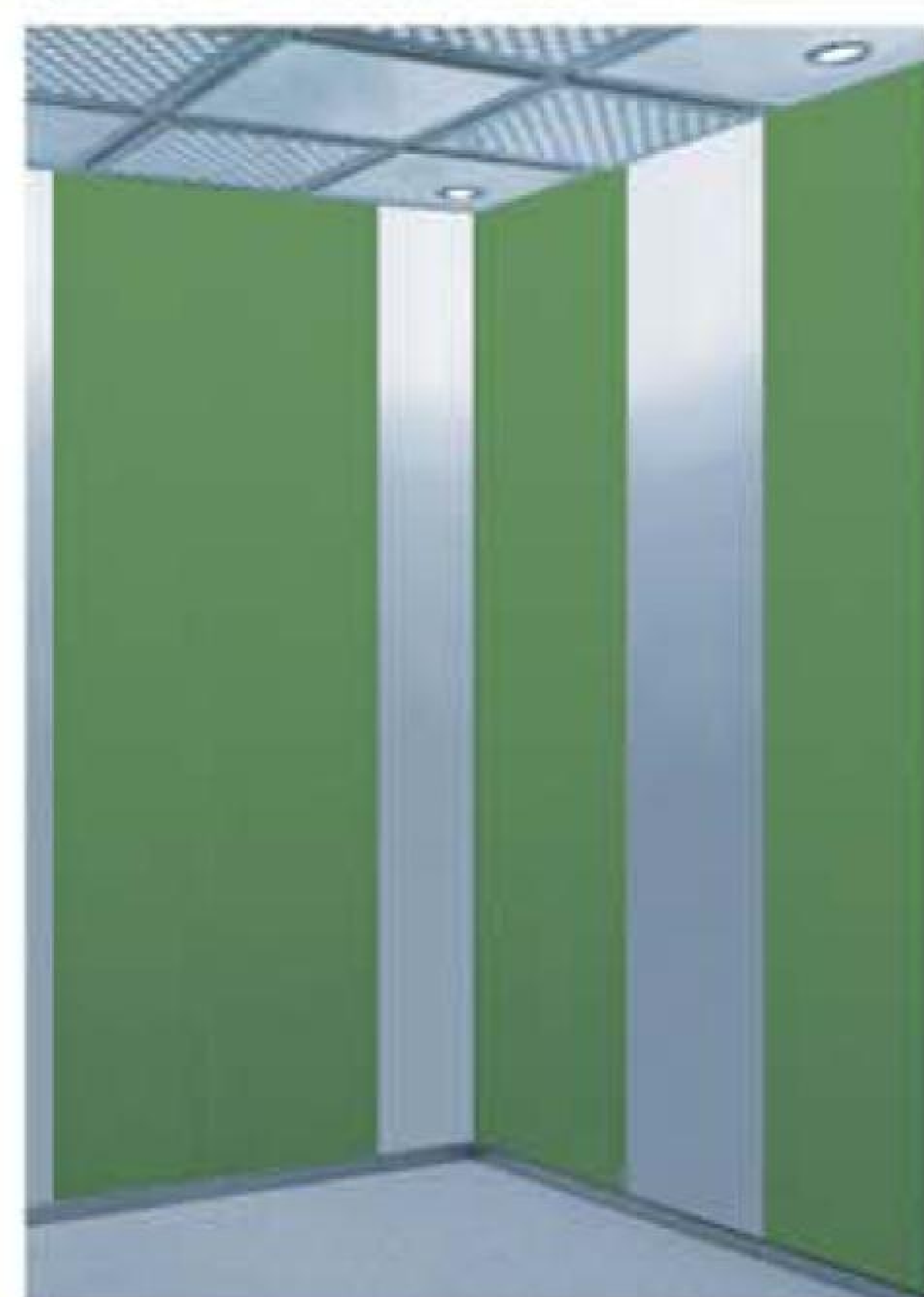

C-S04型轿厢 Car

伟达标准轿厢设计简约时尚,色泽搭配自然,可和谐融合于不同风格的建筑当中。

- 轿壁采用不锈钢和喷粉钢板按美学比例拼接制成;
- 天花可从标准式样中任选;
- 地台选用优质塑胶地板,或预留下陷空间,配合业主铺设心仪之石板材。

WELLIFT standard car is simple in design, fashion in style, nature in luster, which is harmonious with various-style buildings.

- Car wall is patched with stainless steel and spray-powder steel with aesthetic proportion.
- Ceiling is optional in standard styles.
- Floor is high-quality plastic floor, or sunk reservation for stone decoration according host's favor.

### 标准轿厢、厅门喷粉色样选择

Optional color patterns of Standard car and landing doors

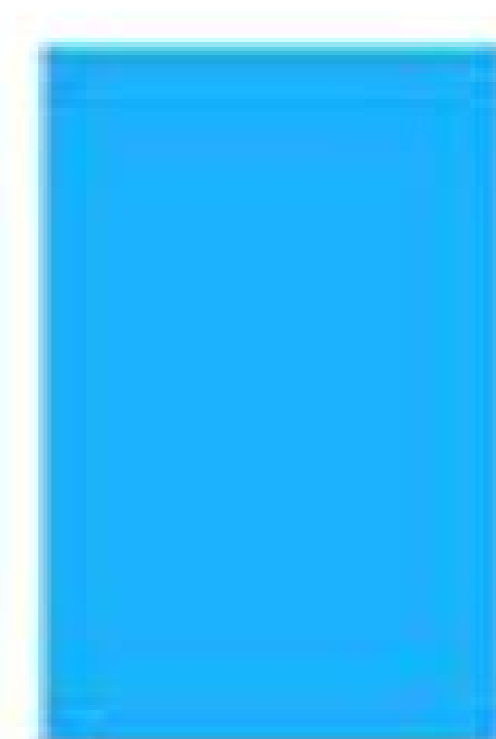

C-01

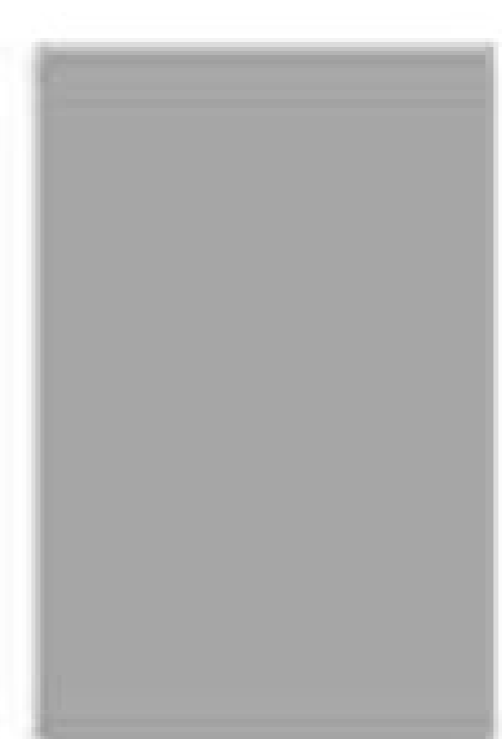

C-02

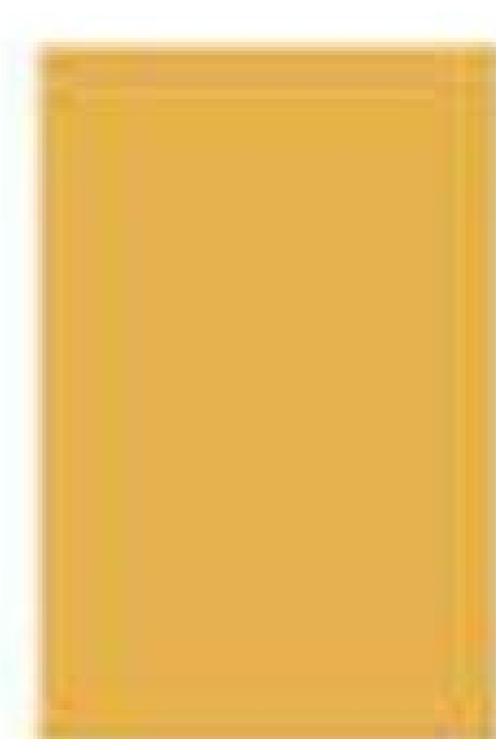

C-03



C-04

S型标准按钮  
S-shape standard button



C型可选按钮  
C-shape optional button



DV-S  
显示器  
Indicator



DB-S  
呼梯盒  
Call box

可选组合 Optional combination



DV-C  
显示器  
Indicator



DB-C  
呼梯盒  
Call box

可选组合 Optional combination



DV-VS  
外呼盒  
External call box



CB-S  
操纵盘  
Integrated control panel

标准样式 Standard mode

## 二十四小时热线服务 24-hours hot line service

伟达电梯设立了24小时服务中心，开通了800免费报修热线，为客户提供了方便、快捷的维修服务，一批训练有素的维修技工随时待命处理每个电话召修。

远程监控系统利用了先进的数据网络和微机处理技术，对电梯实现了24小时中央化远程电子监控，能预测电梯可能存在的故障隐患，实现了有计划地预防性维修服务，极大地提高了电梯的运行质量和安全性。

伟达电梯已在香港、深圳、厦门设立了远程监控中心，并已开通了远程服务系统。

WELLIFT set up the 24-hour service center and put through 800 free-charge call for providing most convenient and prompt maintenance service for customers. There are a batch of skillful maintenance men waiting there for any call at any time.

The long-distance monitoring system adopts advanced data network and microcomputer processing technology, which can perform 24-hour remote electronic monitor on elevator, predict the potential hazards and fulfil preventative maintenance service. It greatly improve the operation quality and safety of the elevator.

WELLIFT has established remote monitoring centers in Hong Kong, Shenzhen and Xiamen, related remote service system has put into use.





## 全球市场 | Market



伟达电梯有限公司  
WELLIFT ELEVATOR CO.,LTD.

厦门市思明区世茂海峡大厦A栋3503室

Room 3503, Tower A, Shimao Strait Building, Xiamen, China.

Tel: 0086-592-5166666 Email: info@wellift.com

[www.wellift.com](http://www.wellift.com)